

ENIGMA
POCKET DOORS

Motus® *Powered*
NFR Visible Trims
Installation Guide

SEL-PRT-00776 | Rev. 5



TRIM TYPE
Visible



FIRE RATING
N/A



ACOUSTIC RATING
N/A



Thank you for choosing Enigma

To ensure the installation process is simple and efficient, we recommended you read this guide in full first.

Specific tools are also required to complete the installation:



Pencil



Tape Measure



Knife

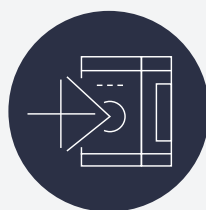

Laser Level



Cordless Drill Driver

Sync Unit Wiring Tools

For Double Doors



Powered
Chop Saw

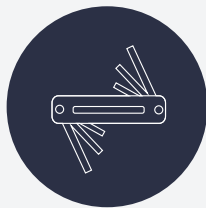

Hex Keys
(Metric)



Flathead Screwdrivers
(Medium & Small)

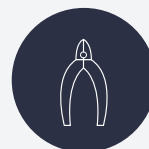

Cable Stripper
& Cutters

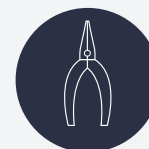

Long-nose
Pliers

Fire certification guidance

IMPORTANT

If fitting a fire rated lock refer to the Global Assessment for intumescent detail or contact Selo.

Flush door handles - Based on the test evidence cited within CNA/F15315 Revision D which permits the machining of the Halspan 30 Prima/Optima door core to a minimum thickness of 18mm in order to achieve a panelled door appearance when using a 54mm overall thick core (in accordance with Section 6.2) or 8mm when using a 44mm overall thick core. Flush door handles may be fitted subject to the limitations below:

1. Where handles are fitted back to back, handle thickness is limited to 9.5mm.
2. Where handles are staggered between the two leaf faces a maximum handle thickness of 13.5mm is permitted, the handle pockets must be separated by a minimum of 100mm of leaf core material.
3. Handle dimensions are limited to a maximum of 600mm in height and 60mm in width at the thicknesses shown above.
4. Handles must be fitted a minimum of 60mm from leaf edges.
5. The pocket formed to receive the handles must be lined with 1mm thick Interdens. Refer to the Global Assessment for intumescent detail or contact Selo.

Getting started

Before you start installation ensure you have read and understood the instructions.

DELIVERY

The Motus Enigma pocket door system will be delivered in three boxes:

1. Pocket Frame
2. Trim Surround
3. Track

If a door leaf has been ordered this will come separately.



POWER REQUIREMENTS

The Motus Enigma pocket door system requires a low-voltage electrical connection. Wiring for the system can vary based on the type of connection:

Hardwired (Optional)

1. 13 amp fused spur isolation switch
2. 1.5mm twin and earth cable feed to the top of the pocket enclosure

'Kettle-lead' Wiring (Standard)

1. 13 amp single socket



IMPORTANT SAFETY INFORMATION

The unit should be installed and commissioned by a trained and qualified personnel.

The unit may only be opened and repaired by the manufacturer.

This unit may only be operated from a protective low-voltage with safe electrical isolation.

Always consider the safety functions of your application as a whole, never just in relation to one individual component of the system.

The installed is responsible for carrying out a risk assessment and installing correctly.

Avoid touching any electronic components.

Motus® Frame kit NFR V

Familiarise yourself with components included. All fixings will come pre-packaged to suit your specific project requirements.

MOTUS FRAME FIXINGS

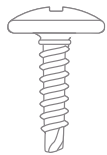

Type-1 - 4.2×13.5mm
 Wafer Head
 Self Drilling
 SEL-PRT-00685



Type-2 - 4.5×40mm
 Countersunk Pozi Single Slash
 Wood Screws
 SEL-PRT-00686



Type-3 - 4×50mm
 Countersunk Pozi
 Wood Screws
 SEL-PRT-00687

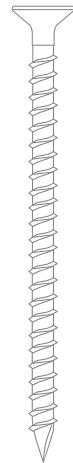

Type-6 - 4.5×60mm
 Countersunk Pozi Single Slash
 Wood Screws
 SEL-PRT-00690

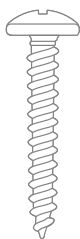

Type-4 - 4×30mm
 Cross Round Head Pozi
 Wood Screws
 SEL-PRT-00688



Type-5 - 3.5×25mm
 Bugle Head Phillips
 Self Drilling
 SEL-PRT-00689



Type-15 - 6.0×80mm
 Countersunk Pozi 3
 Wood Screws
 SEL-PRT-00770

MOTUS FRAME COMPONENTS

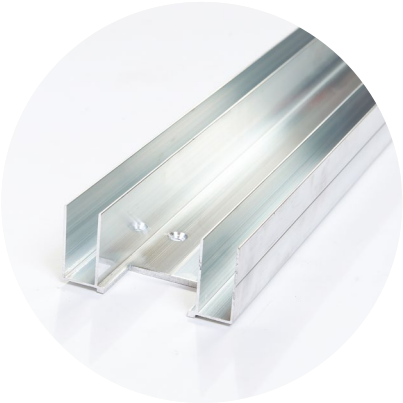

Base Channel

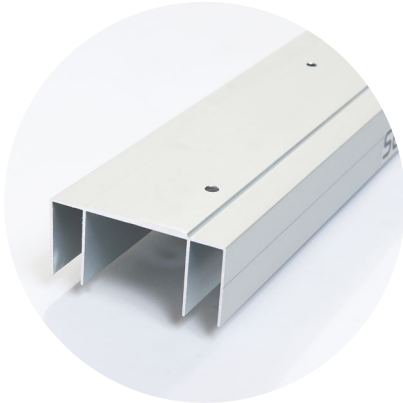

Head Channel



Leading Edge Jamb

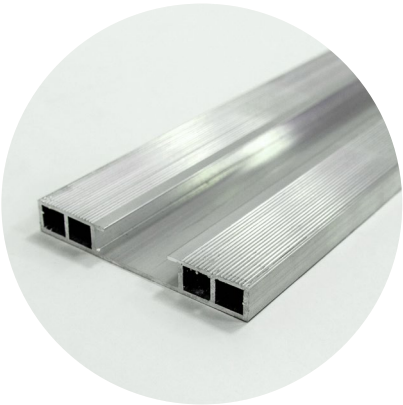

Intermediate Jamb



Timber Insert



Door Guide Pin & Channel



Motus Sliding Track



Brush Strip

Wall construction preparation

The Motus Enigma system can be fitted to steel or timber studwork partitions. You must ensure the head stud is strong enough to take the door weight.

IMPORTANT INSTALLATION NOTES

1. Studwork size

The studwork size required is **94mm**.
If using steel studs a 94mm head and base track and 92mm uprights should be used.

2. Steel studs

If using steel studs, timber inserts are required within the studs to provide additional strength and purchase for 60mm track screws.

3. Doors above 2300mm

If the door height you are installing is above 2300mm then using 2 layers of plasterboard is recommended.

To order kits to suite two layers of plasterboard add 'Double Board' to the product code.

4. Self-supporting Head

For situations in high rise buildings where you cannot fix to the ceiling or soffit then use the Enigma Self-supporting Head installation detail.

Follow standard Enigma instructions to calculate your studwork structural opening and add the following dimensions: **Width +94mm** and **Height +220mm**. Refer to the specific Self-supporting Head installation instructions for further details.

Bespoke requirements?

Enigma can be customised to suit bespoke projects. In principle, the installation process remains the same, however certain installation dimensions may differ.

Please contact the Selo team to discuss your bespoke requirements.

020 3880 0339

Dimensions

Motus NFR V

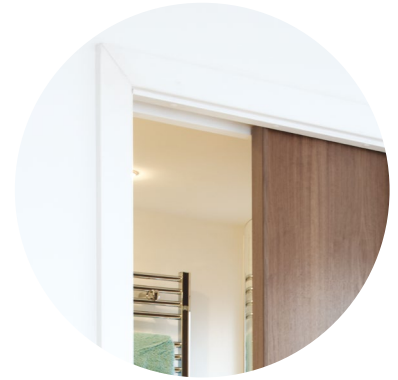

SELF-SUPPORTING HEAD

Follow the standard Enigma instructions to calculate your studwork structural opening and add the following dimensions: **Width +94mm** and **Height +220mm**

IMPORTANT

If installing **Self-supporting Head** please refer to the specific installation instructions for further details.

MOTUS TRACK SIZE

ITEM		1750mm	2000mm	2250mm
Door sizes (mm) Height = S/O -95mm	Width	875	1000	1125
	Min. Height	1500	1500	1500
	Max. Height	2815	2815	2815
Clear openings (mm)	Min. Single	600	845	970
	Max. Single	844	969	1094
	Min. Double	1000	1711	1961
	Max. Double	1710	1960	2210
Structural openings (mm)	Width Single	1870	2120	2370
	Width Double	3700	4200	4700
	Height	Door +95mm	Door +95mm	Door +95mm

Base Channel Calculations

Please refer to Step 4 of the Frame Installation instructions shown on page 12.

A

STRENGTHEN HEAD

When constructing your stud partition, please ensure the head is strong enough to take the weight of the sliding door that will hang from it.

IMPORTANT

If using a **Self-supporting Head** please refer to those specific installation instructions.

B

CHECK SIZE WITH SCHEDULE

When forming the structural opening, please ensure you are working to the correct opening size provided on the door schedule.

C

LEVEL-UP

Ensure the opening is square and plumb.

IMPORTANT

We strongly recommend using a laser level for setting out.





Frame installation

IMPORTANT

If installing **Self-supporting Head** please refer to the specific installation instructions for further details.

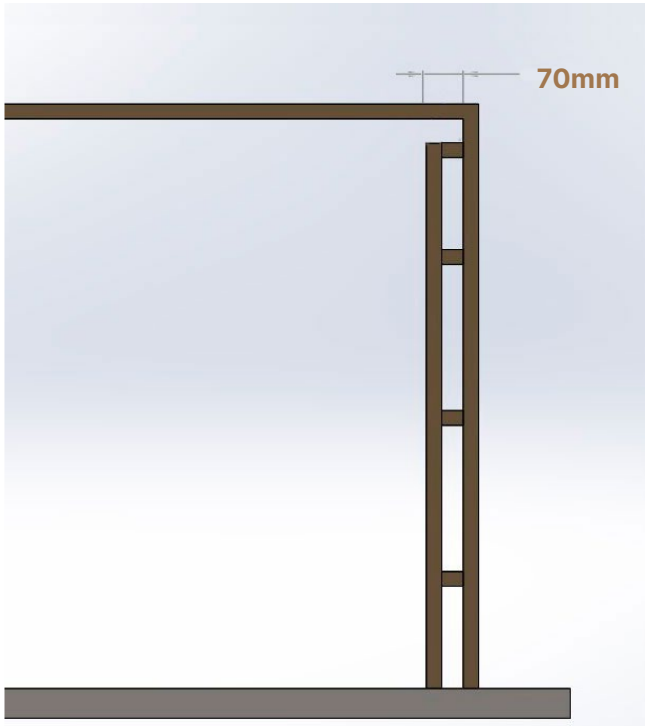

1a

PREPARE THE STRIKE JAMB

IMPORTANT
If installing double doors skip this step.

Cut some C16 timber stud (70mm x 45mm) to the height of the structural opening.

Cut noggins at 26mm thick. Space at a maximum of 500mm centres and fix to the strike as per the drawing.



1b

PREPARE HEAD CHANNEL & SLIDING TRACK

Single doors
Cut the head channel to S/O width.

Double doors
Cut the Head channels equally to take up the whole S/O. It is important to ensure that where the two channels meet is in the centre of the opening.

2

HEAD CHANNEL PREPARATION

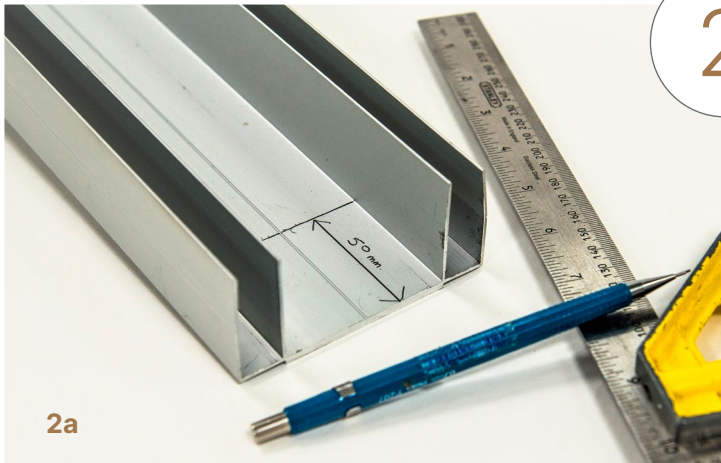

2a

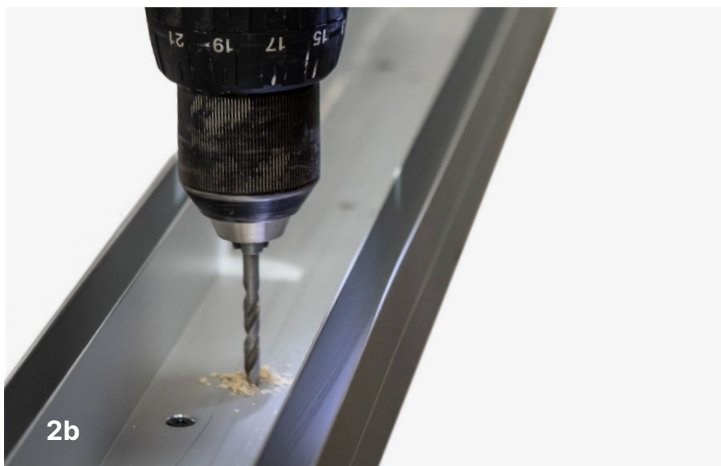

2b

Single doors

2a Mark 50mm from the rear end of the Head channel and 70mm from the strike/front end.

2b The kettle lead port is at the front of the track and will be installed at the strike end of the pocket. Place the Track on the Head channel and line-up the kettle lead entry point with the 70mm mark. Align the centre lines of the Track and the Head channel together, pilot drill the screw holes.

Double doors

Mark 50mm from each end. The Tracks will be installed with the kettle lead ports in the middle to aid wiring. Place the two Head channels together with the tracks inside lining up the centre lines. Ensure there is 100mm gap between the tracks for the wire box and then pilot drill the screw holes.

3

FIT THE HEAD CHANNEL



Using a laser level, fit the head channel to the top stud with Head Channel screws.

IMPORTANT

It is important to ensure the Head channel is level with no bends or bows. If the top stud is not straight then pack the head channel out with packers to maintain level.

Single doors

The 70mm gap and the kettle lead port should be at the strike end of the pocket.

Double doors

For double ensure the kettle lead ports are facing each other in the centre of the opening and with 100mm gap between the tracks.

4

CALCULATE BASE CHANNEL & FIX

Base channel length

Single doors NFR V

Structural Opening (minus) - Clear Opening (minus) - 130mm

Double doors NFR V

Structural Opening (minus) - Clear Opening (minus) - 64mm ÷ 2

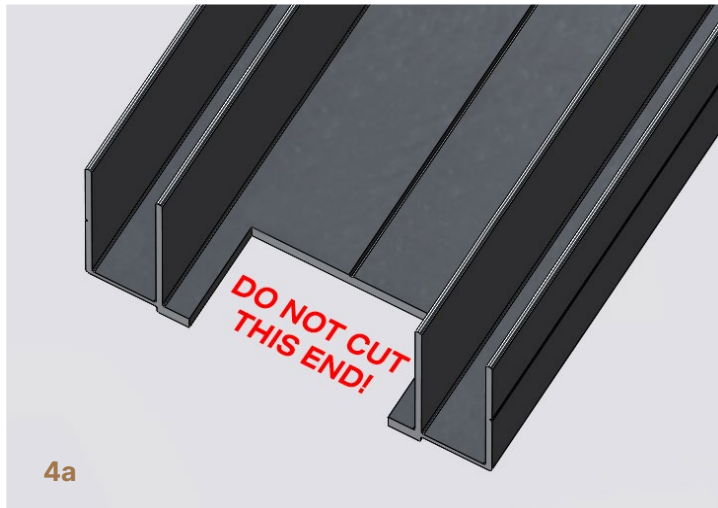

Single/Double doors

To accurately determine the length of the Base channel, refer to the calculations on the left.

Cut the Base channel to this dimension. Do NOT cut-off the end with the notch.

Image 4a

Base channel fitting

Place the Base channel on the floor against the rear stud.

If provided with a 'cut-to-size' system position the notched end tight against the rear stud.

At this stage it is vital that to ensure that the centre line of the Base channel is secured directly underneath the centre line of the track above. Any deviation will result in misaligned doors and trims. Secure to the ground with Type-2 fixings.

Cover-plate (Non- Sync)

If the Sync unit is not used, screw the cover-plate provided between the tracks to cover the cable.

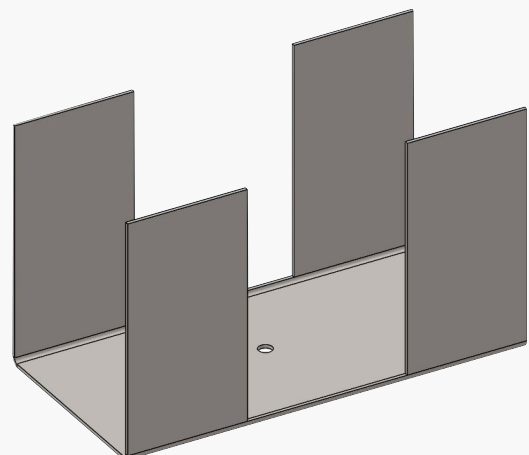

System calculations

Structural opening examples*

1750mm wide

Single S/O	1820mm (Track +70mm)
Double S/O	3600mm (Track x2 +100mm)
Max. movement range	875mm

2000mm wide

Single S/O	2070mm (Track +70mm)
Double S/O	4100mm (Track x2 +100mm)
Max. movement range	1000mm

2250mm wide

Single S/O	2070mm (Track +70mm)
Double S/O	4100mm (Track x2 +100mm)
Max. movement range	1125mm

*S/O height Door leaf +95mm

Permitted door leaf sizes

Min. height	1500mm
Max. height	2815mm
Min. width	875mm
Max. width	1125mm

Travel for unit = The amount which goes into the strike jamb.

5

FIT TOP TRACK



5a - Track Tongue

5a Using x4 Type-9 Screws fix the Track Tongue in place ensuring it is central inside the Head Channel and up against the rear Stud, as shown.

5b Slide the rear of the Track into the Track Tongue, then, using the Type-17 screws; fix the remaining x2 screw holes located at the Front and Middle of the Track (NOT the Rear).

Once fixed in place, the front of the Track should be lined-up with the 70mm mark for a Single Door, or 50mm mark for Double Doors. (Detailed in Step 2).

IMPORTANT

Do not fix the rear of the Track (where the tongue is holding the Track in place) This is to ensure that the Track can be removed if required for servicing.



5b - Track

6

CUT LEADING EDGE & INTERMEDIATE JAMB



Cut the Leading edge jamb and Intermediate jamb 15mm less than the structural opening height.

7

CUT & FIT INTERMEDIATE TIMBER INSERT

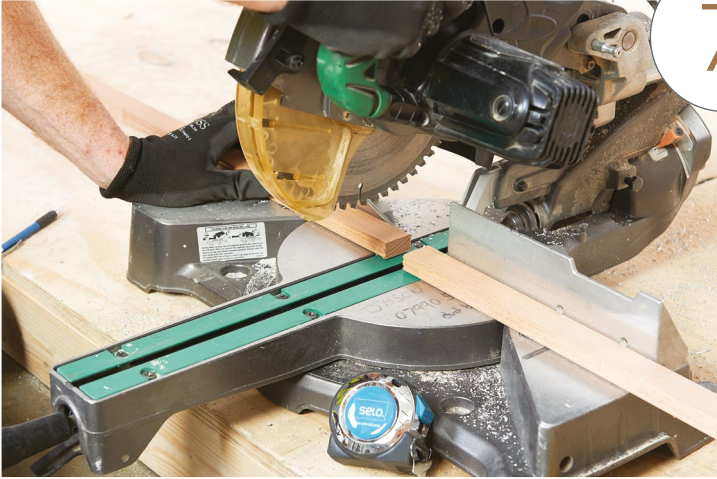

Cut the intermediate Timber insert 100mm shorter than the aluminium jamb and slide the insert into the Intermediate jamb so it sits 50mm from each end.

IMPORTANT

When using door leaves wider than 926mm the kit will be supplied with extra intermediate jambs to be fitted equally space within the pocket width.



8

CONNECTING THE TRACK

Single doors

Push the kettle lead in the strike end of the track. Run the excess cable behind the strike trim packer to the plug. **DO NOT** power on at this point.

Double doors

Remove the kettle lead ports on both tracks. As standard; Motus Double doors utilise a Sync unit to open both doors at the same time, additional wiring is required - See p18.

For Hardwired power supply please see p32.



9

FIT POCKET SIDES & FIX THE JAMB



9a

9a Slide the Intermediate jamb into the Head channel and Base channel with the Timber inserts facing out so it sits centrally in the pocket. Fix using Type-1 screws.

9b Slide the Leading edge jamb into Base channel with notched end at the top, so the flange sits hard against the end of the Base channel.



9b

Plumb the jamb and fix into place using one Type-1 screw top and bottom as shown in the image. Must be posited furthest from the opening.

10

FIT BRUSH STRIP

Cut the Brush Strip to length and fit to the leading edge aluminium profile.

IMPORTANT

If using simultaneous opening ensure that the door leafs and head trims have been fitted. Refer to the simultaneous opening instructions for more.



Door leaf installation

The door leaf needs to be hung before the trim is fitted.

1

FIT HEAD BRACKETS

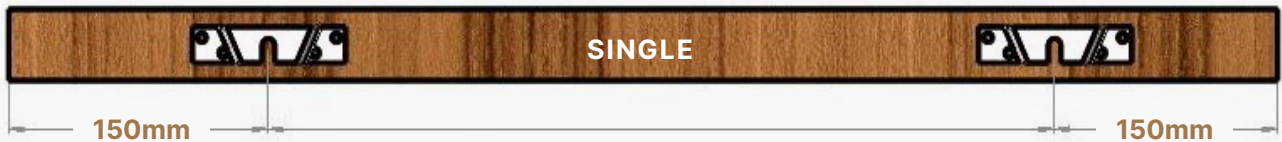

Single Door Position the brackets equally to the edges of the door, spaced to 150mm centres.

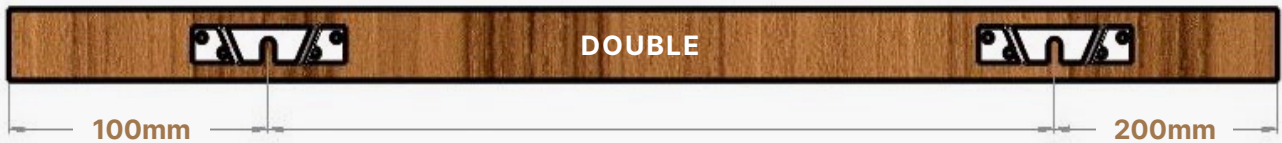

Double Doors Fit brackets 100mm from the back edge and 200mm from the front so the two doors meet in the centre over the 100mm sync unit. (Instead of hanging equally as per the singles.)

2

FIT THE GUIDE CHANNEL

Apply a thin bead of adhesive into the groove in the bottom of the door and then tap the plastic channel into position.



3

ASSEMBLE GEAR



Adjust the bolts to achieve a gap approximately 15mm between the underside of the track and the top of the bolt.

4

HANG THE DOOR



4a

4a The bracket fits onto the bolt as shown.

4b Feed the rest of the door at least halfway into the pocket and hang the front bracket onto the trolley bolt.

4c With spanners provided, wind the bolts up or down to plumb the leading edge of the door and to achieve the required gap under the door (door undercut).

Tighten the locking nuts to secure the door to the brackets. They may need to be slacked-off later, to true the door to the trims once they are fitted.



4b



4c

5

FIT THE DOOR STOPS



Slide the Door stop into the track, fix into place by tightening the grub screws. This can be finally adjusted once the trims are installed. To set the rear stop, slide the door back into the pocket until the door will be flush with the leading edge trims, then tighten the stop up against the carriages.

IMPORTANT

It is important to set the rear stop at this point as once plasterboard is installed there is no access to rear stop.

SYNC FOR DOUBLE DOORS ONLY

A

DRILL HEAD CHANNEL

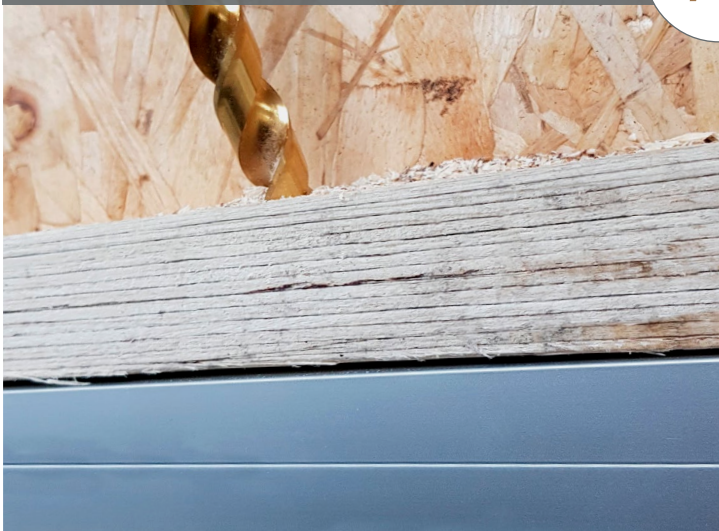
**IMPORTANT**

The next steps A-E refer to the installation of a Sync unit and is used with Double doors ONLY. For Single door installation please skip the following steps.

Work out in relation to your current internal wall cabling as to the route to the centre of the tracks, then drill a hole no smaller than 8mm in the Head Channel as shown.

SYNC FOR DOUBLE DOORS ONLY

B

REMOVE KETTLE-LEAD PORTS



Remove the fascias on both tracks to expose the kettle lead port and connection terminals.

Remove x2 screws before removing port. Ports need to be removed from both tracks.

IMPORTANT

Do not bend-down switchboard when removing the ports.

SYNC FOR DOUBLE DOORS ONLY



C

PREPARE CABLE

Cut the Kettle-lead plug off the power cable supplied and thread through the Head Channel hole drilled previously.

Strip the cable approximately 30mm from the ends.

SYNC FOR DOUBLE DOORS ONLY



D

CONNECT TRACKS

Wire the block to the Tracks as shown.

Connect the two Tracks together with the Sync-cable provided in the plugs shown.

SYNC FOR DOUBLE DOORS ONLY

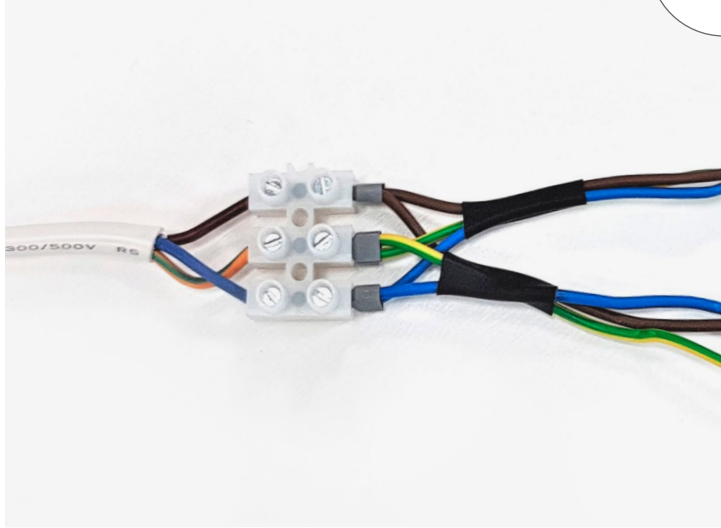

E

WIRE POWER CABLE

Wire the power cable to the connector block as shown then 'power-up' the track.

6

CALIBRATE TRACKS



Prior to configuration ensure doorstops are correctly fitted to avoid any potential damage.

Power-up the Motus. Press-and-hold the 'reset' button (both tracks if installing a Double door) for 3 seconds - The LED light will flash, let go and stand clear of the door(s) while it self calibrates. Usually the door will open/ close 2-3 times during the process. Adjust the door levels so it closes straight against the strike jamb.

IMPORTANT

The tracks must have the same Speed/Delay times to sync correctly. These can be adjusted with the plastic screwdriver (enclosed).

Do not over turn the adjustment screws; only turn between Min and Max indicators.

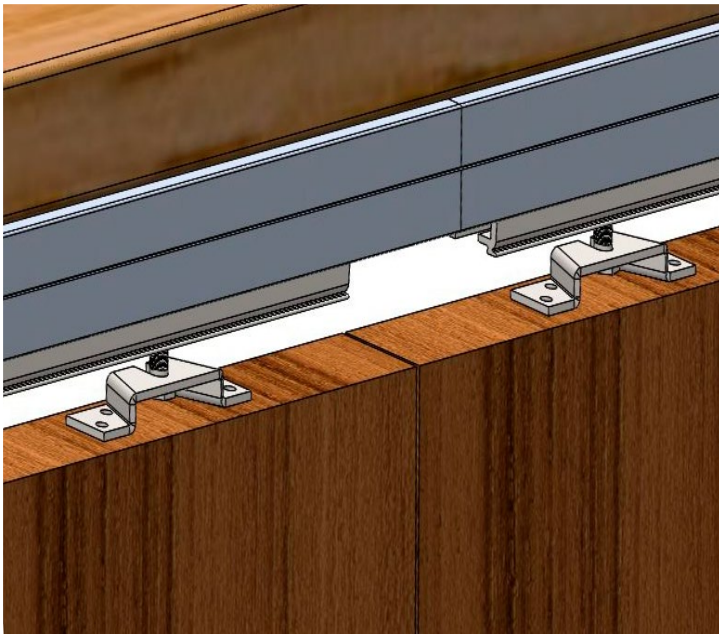

SYNC FOR DOUBLE DOORS ONLY



Test the doors to ensure correct movement/function. Attached the Cover Plate to cover the gap and screw into place.

7

FIT DOOR GUIDE PIN

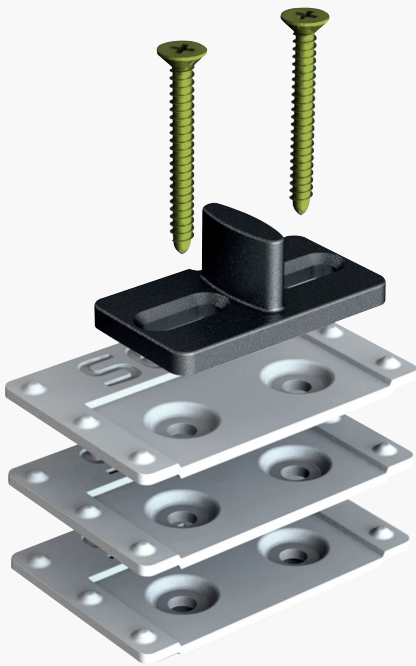

Fit the door guide pin at the finished floor level with Type-2 fixings. The pin needs to be facing the strike stud and aligned centrally with the centre line on the base channel.

If your installation requires the door guide pin to be raised up - use the 1mm stackable packers.

IMPORTANT

1. The pin needs to be fitted at FFL (finished floor level). If the finished floor is not yet installed, fitment of the floor pin can be delayed until the flooring is completed.

8

PLASTERBOARD ONE SIDE

Plasterboard over one side of the pocket along with the rest of the wall using the Type-5 self drilling screws provided. It is vital to ensure the leading-edge jambs remain completely vertical and plumb once boarded. It is essential to clear any swarf or debris that may be in the top track and bottom channel at this stage.



Motus[®] Trim kit NFR V

All fixings will come pre-packaged to suit your specific project requirements.

SUPPLIED TOOLS

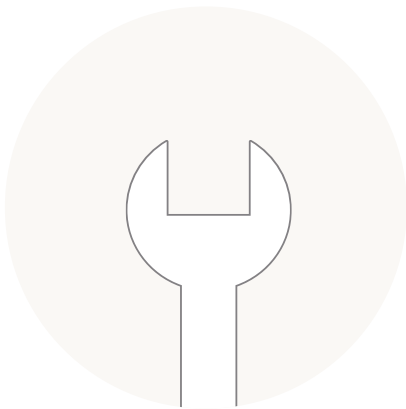

Spanner

VISIBLE TRIM FIXINGS



Type-5 - 3.5×25mm
Bugle Head Phillips
Self Drilling
SEL-PRT-00689

VISIBLE TRIM FIXINGS (cont.)

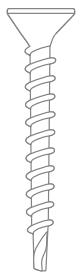

Type-7 - 3.5×32mm
Bugle Head Phillips
Self Drilling
SEL-PRT-00691

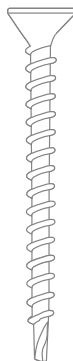

Type-8 - 3.5×42mm
Bugle Head Phillips
Self Drilling
SEL-PRT-00692



Type-9 - 5×50mm
Countersunk Pozi Single Slash
Wood Screws
SEL-PRT-00693



Type-13 - 1.4×25mm
Panel Pins
SEL-PRT-00531

VISIBLE TRIM COMPONENTS

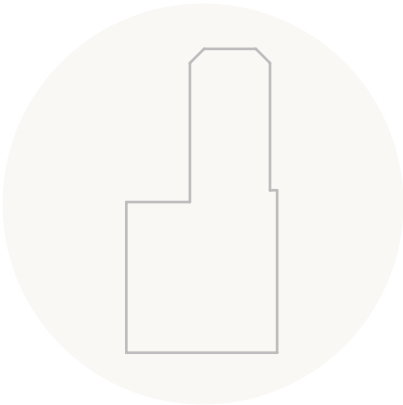

Head Trim

Single door x1 / Double door x2

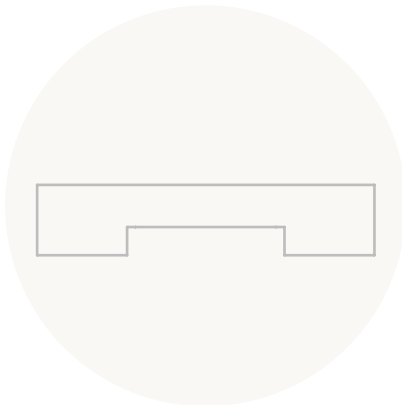

Strike Trim

Single door x1 / Double door n/a



Leading Edge Trim

Single door x2 / Double door x4



Strike Jamb Seals

Visible trim installation

Now the door leaf is hung you are ready to install the trim.

1

INSTALL LEADING EDGE TRIM



Cut the Leading Edge Trims to the height of the opening and slot them over the flange on the leading-edge aluminium jamb, with the grooves for the intumescent seal facing in towards the door.

They must be secured into position with the Type-5 screws at 300mm intervals. Please note that the timber will need to be pilot-holed first.

2

LINE THE DOOR UP



If required, the door can now be trued into alignment with the leading-edge trims by adjusting the hanger bolts up or down as necessary.

When you're happy that everything is aligned and the gaps between the door and trims are equal, lock the bolts firmly into position by winding down the locknuts.

IMPORTANT

Maximum undercut must not exceed 8mm.

3

INSTALL STRIKE TRIM

Dimension =
Underside of
head profile
to floor

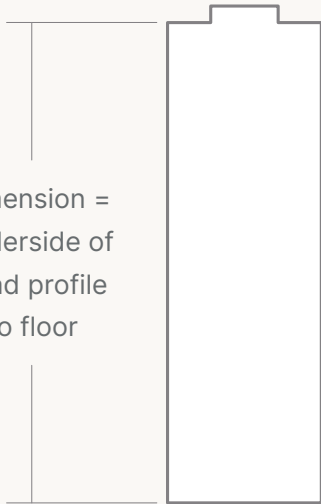

Cut the Strike trim as per the drawing measuring from the notch to the end that is not notch. Cut the end that is not notched.

Then fit the notched end centrally in the Head channel. Plumb the strike trim using a level so it is aligned centrally with the Head channel and fix into place using the Type-9 screws.

IMPORTANT

When installing double doors the strike jamb is not used.

4

SET CLOSER STOP



Adjust the metal clip, so the door leaf closes and is held in place, against the strike jamb.

5

INSTALL THE HEAD TRIM



Cut the Head trim the distance between the two timber side jambs. Slot into place in the head and fix using Type-5 screws.

6

TAPE & JOINT / PAINT

Now the wall can be tape and jointed and wall and trims painted.

IMPORTANT

We recommend tape and jointing not plastering.

7

FIT STRIKE SEALS

Fit the rubber seals to the corners of the strike trim as shown in the illustration.







Troubleshooting

Technical support helpline **020 3880 0339**

halo
assist

MALFUNCTION	POSSIBLE CAUSES	REMEDY
Door is switched on Door is not responding Green LED is off	No power supply available	Check power supply
	Power cable connection not firmly plugged in	Plug in the power cable connection firmly
	Power cable defective	Replace power cable
	Mains plug defective	Replace drive
Door not responding Green LED lights up	Program switch in position [0] (OFF)	Switch program switch to the desired position
	Program switch in position [II] (PERMANENTLY OPEN)	Switch program switch to the desired position
	Door was opened by double-clicking PERMANENTLY OPEN switched on	Close the door by double-clicking again
	Safety sensor on the door is active (obstacles in the sensor's detection area)	Remove obstacles and adjust safety sensors if necessary
	Cable to sensor defective	Check cable and replace if necessary
	No safety sensors connected	Check jumpers and replace if necessary Terminals must be jumpered
	Drive defective	Replace drive
LED flashes green	Learning cycle was not completed	Restart learning cycle
	Drive defective	Replace drive
Door stops while moving	Door moves stiffly	Check the door's area of movement and eliminate any reason for the stiffness
		Check track and floor guide for dirt or wear and clean if necessary
Door moves past the set OPEN or Closed position	Corresponding end stop has shifted	Readjust and retighten end stop Carry out a learning cycle
Red LED lit up constantly	Control defective	Turn the power switch off and then on again
		Replace drive

Red LED flashes cyclically 2 times	Control defective	Turn the power switch off and then on again Replace drive
Red LED flashes cyclically 3 times	Power range switch has been switched over	Turn the power switch off and then on again
Red LED flashes cyclically 4 times	Testable safety sensors defective	Check safety sensor and replace if necessary
	Sensor's cable defective	Check cable and replace if necessary
	DIP switches 1 to 3 set incorrectly	Check and reset DIP switch settings
Red LED flashes cyclically 5 times	Incremental encoder or incremental encoder cable defective	Turn the power switch off and then on again Replace drive
	Opening width set incorrectly	Reset opening width (end stops) Carry out a learning cycle
Red LED flashes cyclically 6 times	Door's area of movement is blocked	Clear the area of movement
	Opening width set incorrectly	Reset opening width (end stops) Carry out a learning cycle
Red LED flashes cyclically 10 times	Stator or stator cable defective	Turn the power switch off and then on again Replace drive
	Short circuit at the connection terminal	1. Eliminate short circuit 2. Turn the drive off and then on again using the power switch
Hum in final position	Unfavourable end position of the door leaf	Move end stop by at least 2 mm Carry out a learning cycle
Door leaf vibrates while moving	Guide mechanism is tight	If necessary, readjust the door leaf connection and floor guide Rotate nuts several times to fix door leaves

Dip Switch Settings

Activate different inputs at the connection terminals via the Dip Switches to adjust operation modes.

- | | |
|--|--|
| 8 OFF = No locking function | ON = Locking function |
| 7 OFF = Reduced closing force | ON = Enhanced closing force |
| 6 OFF = Automatic Function activated | ON = Permanent Open Function activated |
| 5 OFF = External motion detector activated | ON = External pushbutton activated |
| 4 OFF = Internal motion detector activated | ON = Internal pushbutton activated |
| 3 OFF = Test low active | ON = Test high active |
| 2 OFF = Sensor test at secondary closing edge deactivated | ON = Sensor test at secondary closing edge activated |
| 1 OFF = Sensor test at main closing edge deactivated | ON = Sensor test at main closing edge activated |



Hardwired power supply

How to hard-wire a permanent power supply to your Motus powered Enigma pocket door system.

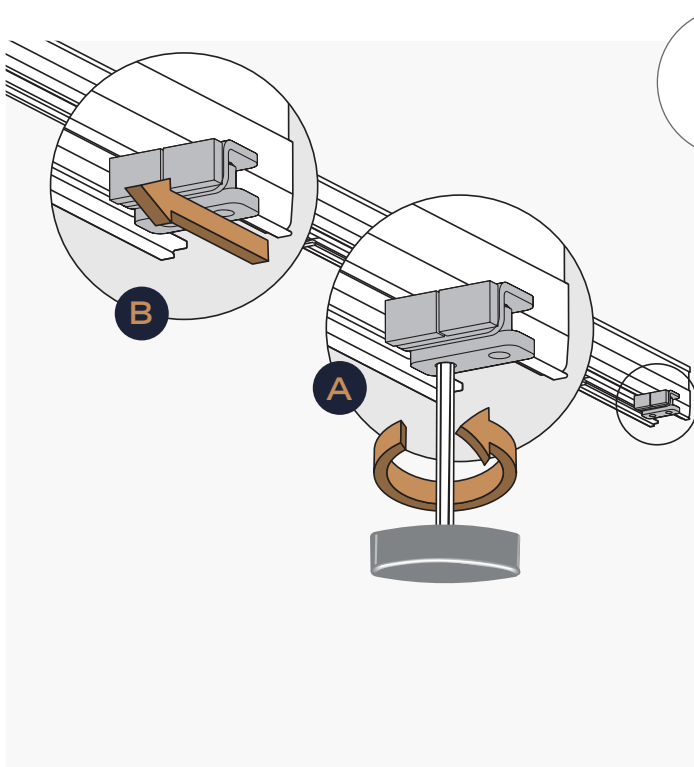
**1**

MOVE END STOP

When the system is installed with permanent power supply, the internal power supply socket has to be removed.

Loosen the screws at the end stop and move the end stop to the centre of the system.

IMPORTANT

Do not remove or screw down the end stop.

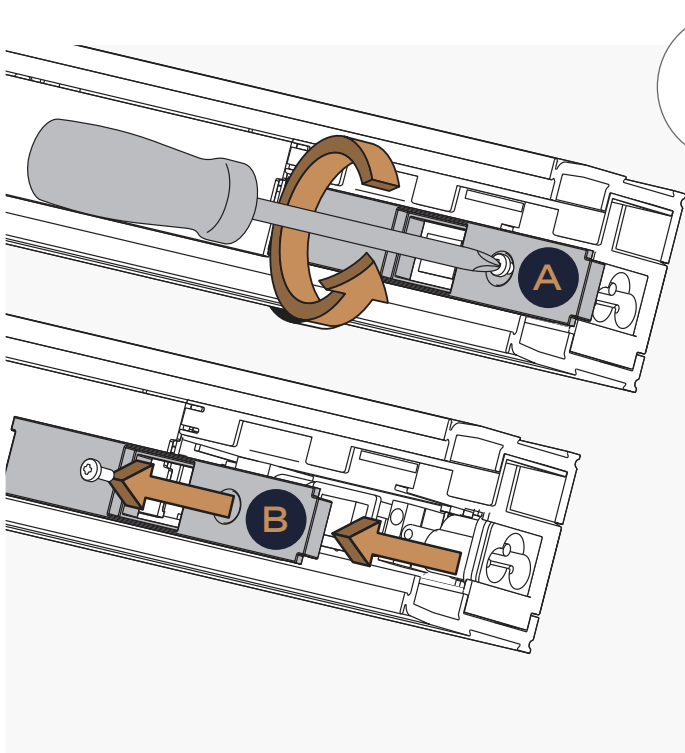
**2**

REMOVE POWER SUPPLY COVER

Loosen the screw in the cover of the power supply housing and remove the cover (on the side where the connections are located).

IMPORTANT

Keep the cover and the screw in a safe place as you will require it later.

3

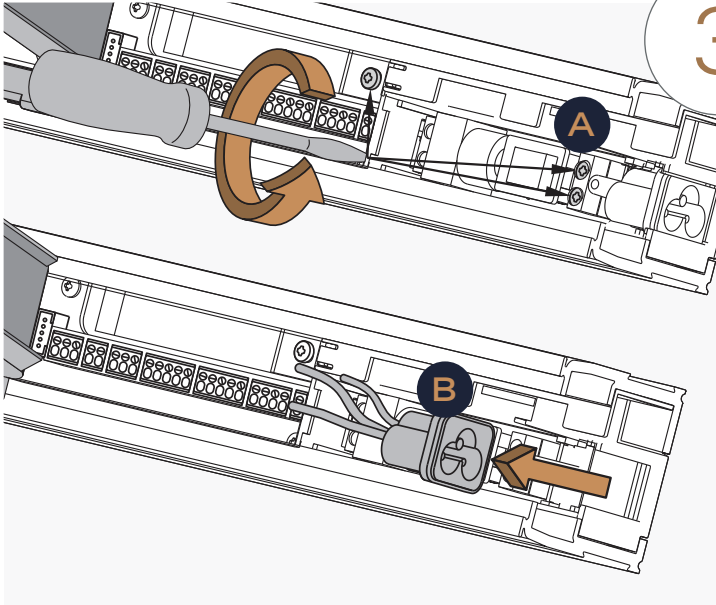
REMOVE INTERNAL SOCKET

Carefully open the cover of the control unit housing by levering it out with the tip of a flat-bladed screwdriver.

Relax the screws of the connection terminals and remove the internal shockproof socket.

4

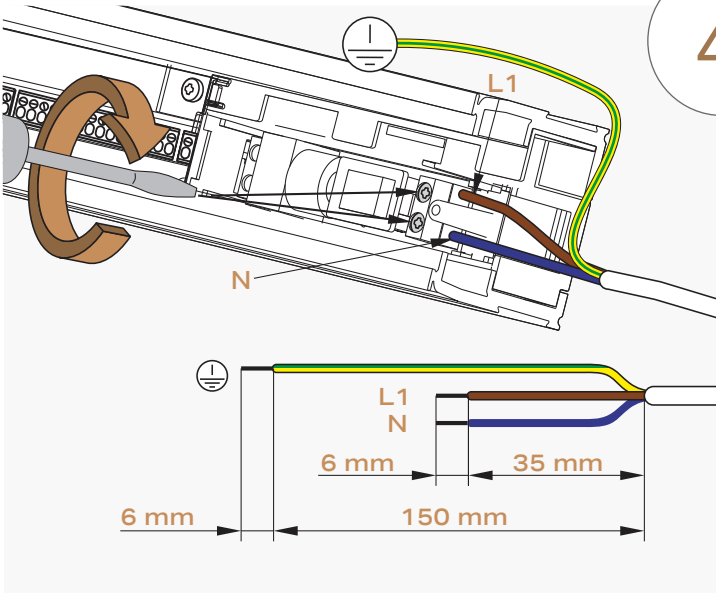
LIVE & NEUTRAL CONNECTIONS

Cut the leads to length, dismantle them and connect L1 and N to the connection terminals of the power supply as shown.

IMPORTANT

Before starting with the installation, make sure that the power supply line is dead (de-energized).

5

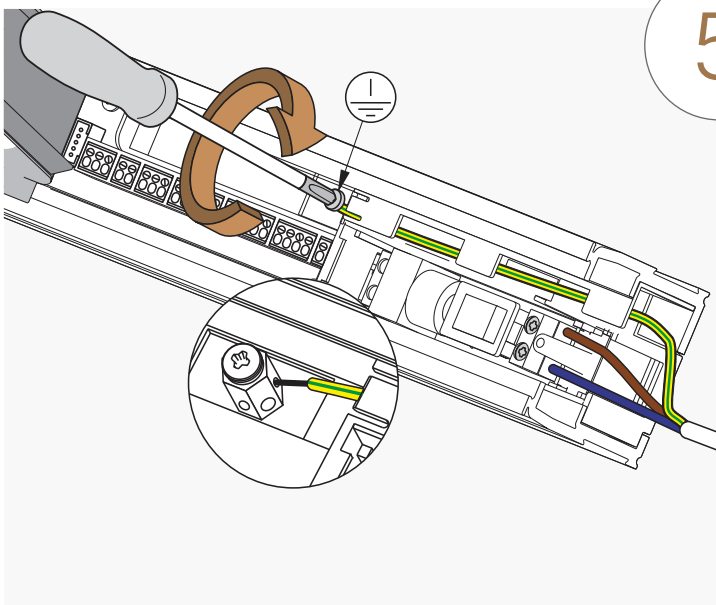
EARTH CONNECTION

Lay the grounding line through the housing of the operator as shown in the picture and connect it to the grounding terminal (PE).

6

CONNECT EXTERNAL ACCESSORIES

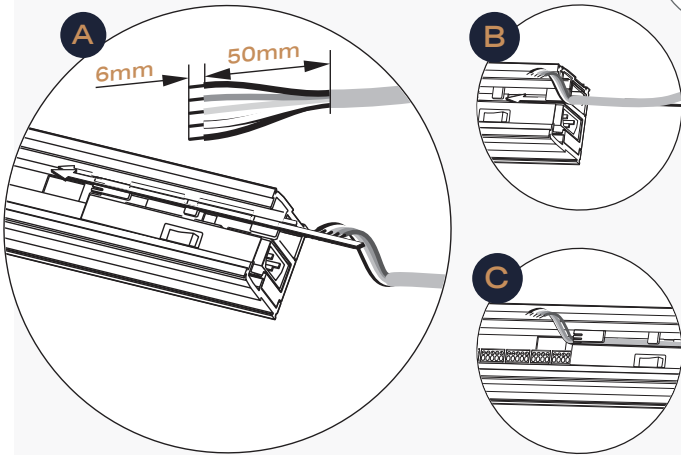

Connect all external accessories, except safety sensors. The cables for Sensors, Push-buttons etc have to be laid inside a cable channel as indicated in the picture.

If additional Accessories are not required move to next Step.

7

CLOSE AND SCREW-DOWN COVERS

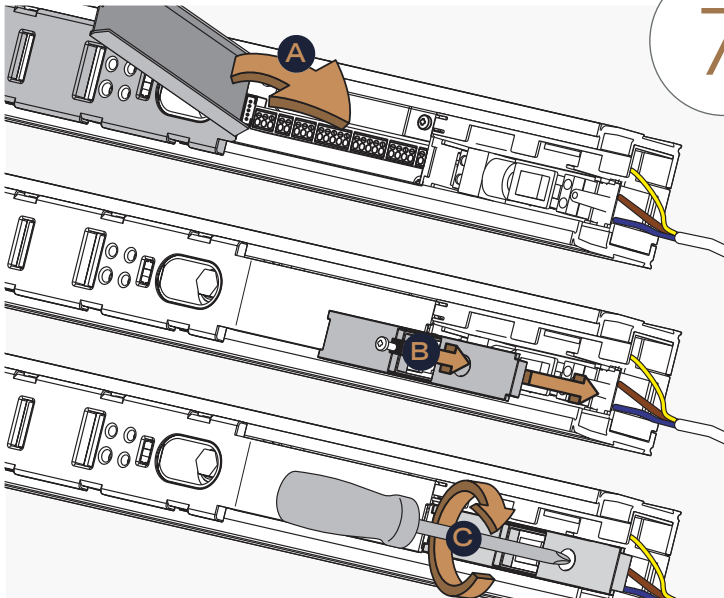

Close the cover of the control unit housing. Fix and screw down the cover of the power supply housing.

8

RETURN END STOP

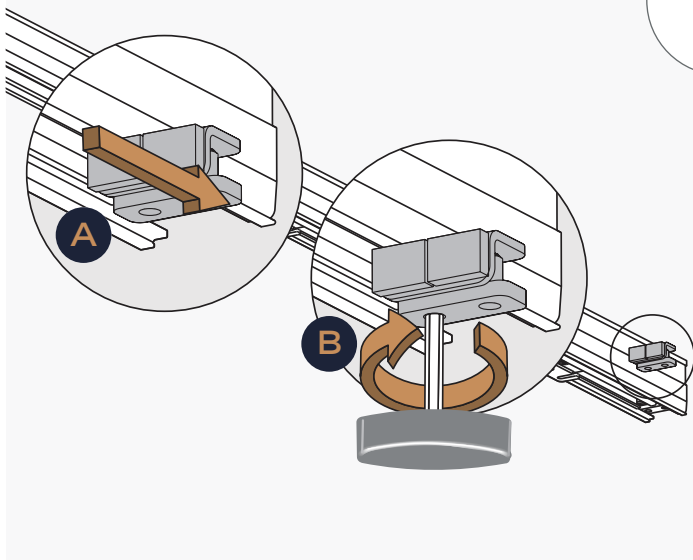

Move the end stop to the end of the channel and screw it down thoroughly.

IMPORTANT

The end stop must not overlap.

Commissioning and inspection

These checks should be carried out on a routine basis to be determined based on risk assessment.

RISK ASSESSMENT GUIDANCE

Low energy movement of the doorset is generally not protected with additional protective devices because the kinetic energy levels are not considered to be hazardous. However, use of low energy doorset movement should only be considered when the risk assessment has taken account of elderly, frail and disabled users and indicates that the risk to these users is low.

The result of the final verification and operational tests should be recorded in a log book. The log book shall refer to applicable instruction for use and shall have space available to record:

1. All maintenance and repairs carried out, including recommendations (Improvements, replacements etc)
2. All significant changes or upgrading carried out
3. Any work undertaken to the doorset
4. Name, date, signature of designated responsible person
5. Include copies of the 'Check Details' table below, filled out at periods defined in the risk assessment

INSPECTION RECORD			Signed	Date	
	✓ or ✗	Initials		/	/
Risk assessment carried out within the last 12 months.	<input type="checkbox"/>	<input type="text"/>			
Check door and pocket condition ensuring no sharp edges* or other hazards. Check all essential components are fitted and in serviceable condition. <small>*If flush handles are fitted then the doors stop should be set so the handle remains out of the pocket when open to mitigate risk of injury.</small>	<input type="checkbox"/>	<input type="text"/>			
Isolate the power to the doorset and check to ensure manual operation is achievable.	<input type="checkbox"/>	<input type="text"/>			
Restore power and check door cycles twice whilst initiating, led lamp should remain green when finished.	<input type="checkbox"/>	<input type="text"/>			
Test door closing time (see Table F.2 Min Time for 90% Travel Distance).	<input type="checkbox"/>	<input type="text"/>			
Test auto reverse function works when the door contacts an obstruction.	<input type="checkbox"/>	<input type="text"/>			
If auto close is enabled ensure users are aware of this function.	<input type="checkbox"/>	<input type="text"/>			
If switches are present, check condition and function.	<input type="checkbox"/>	<input type="text"/>			
If additional sensors have been fitted following risk assessment check condition and function.	<input type="checkbox"/>	<input type="text"/>			

Table F.2 - Minimum Travelling Time per Doorset vs. Mass of Door Leaf

Mass of Door Leaf (Kilogram)	80kg	70kg	60kg	50kg	40kg	30kg	20kg	10kg	90% Travel Distance Per Leaf (Meters)
Max. Travelling Speed (Meters/Sec)	0.21mps	0.22mps	0.24mps	0.26mps	0.29mps	0.34mps	0.41mps	0.58mps	
Min. Travelling Time (Seconds)	3.5s	3.2s	3.0s	2.7s	2.5s	2.1s	1.8s	1.3s	0.7m
	3.9s	3.7s	3.4s	3.1s	2.8s	2.4s	2.0s	1.4s	0.8m
	4.4s	4.1s	3.8s	3.5s	3.1s	2.7s	2.2s	1.6s	0.9m
	4.9s	4.6s	4.3s	3.9s	3.5s	3.0s	2.5s	1.8s	1.0m
	5.4s	5.1s	4.7s	4.3s	3.8s	3.3s	2.7s	1.9s	1.1m

The Pocket Door *Movement*[™]

Save Space. Improve Accessibility. Increase Value.

www.enigmapocketdoors.com

